

IRB 6650S

Industrial Robot



The IRB 6650S is the shelf robot form of the Power Robot family which offers a unique working envelope. It is capable of a full vertical and horizontal stroke motion, as well as an increased forward and downward reach. This combination offers new possibilities to robot functions in numerous application areas.

IRB 6650S is reliable with a high production up time, fast with short cycle times and strong with maximized utilization. Its main applications are machine tending, material handling, spot welding and die casting.

Material Handling

Owing to its longer reach forward and down, when put on an elevated track it can supervise twice as many inlet conveyors with different part sizes as a traditional ceiling mounted or wall mounted track with a 5- or 6-axes robot. When compared with an inverted track and a 5 axes robot, the length of the track for the IRB 6650S can be kept much shorter and thereby simplifying installation and reducing total costs.

Injection Moulding

The IRB 6650S is especially suited for large injection moulding machines over 1,000 tons. The flexibility of the six axis robot facilitates post process applications like flaming and assembly operations.

Die Casting

The unique working envelope ensures easy access for die spraying as well as part handling. The process cabling is protected within the robot arm system, thus improving the lifetime of the process cabling.

SpotWelding

The IRB 6650S offers the possibility to improve robot density in framing stations; the key is to place the robots at different levels. The standard IRB 6700 robot can be mounted at floor level and the IRB 6650S be placed at about 1.5-2m above floor level. By this the standard robots perform spot welding operations at the lower part of the car body and the IRB 6650S of the upper part of the car body. Thus making efficient use of space in the framing cell.

Press Tending

The IRB 6650S can handle extremely large sheets, such as complete car body sides. The working area of the robot makes it possible to retract the robot from the press even with large grippers and parts. High acceleration power is combined with a unique stroke horizontally as well as vertically. This unique combination will shorten cycle times considerably and thereby increase production capacity. The working area below the robot offers an excellent opportunity for fast tool changing of grippers.

LeanID Dress Pack

The IRB 6650S is available with LeanID Dress Pack, an option that improves the possibility with many complex wrist movements and where the need for flexibility in changing products is high.

Specification

Robot version	Reach (m)	Handling capacity (kg)*	Center of gravity (kg)	Wrist torque (Nm)
Without LeanID				
IRB 6650S-90/3.9	3.9	90	360	495 ¹ 438 ²
IRB 6650S-125/3.5	3.5	125	360	1037 ¹ 526 ²
IRB 6650S-200/3.0	3.0	200	365	1264 ¹ 625 ²
With LeanID				
IRB 6650S-90/3.9*	Not available with LeanID			
IRB 6650S-125/3.5*	3.5	100	300	1259
IRB 6650S-200/3.0*	3.0	190	300	896
Number of axes	6			
Protection	Std: IP67. Option: Foundry Plus 2, High pressure steam washable			
Mounting	Shelf			
Controller	IRC5 Single Cabinet			

* Extra loads can be mounted on all variants. 50 kg on upper arm and 250 kg on frame of axis 1. ¹Axis 4 and 5, ²Axis 6.

Performance (according to ISO 9283)

IRB 6650S	
Position repeatability	0.15 mm
Path repeatability	1.00 mm

Actual values are equal or below the given values.

Technical information

Electrical Connections

Supply voltage	200-600 V, 50/60 Hz
Energy consumption	2.4 kW

Physical

Robot base	1136 x 864 mm
Robot weight	
IRB 6650S-90/3.9	2275 kg
IRB 6650S-125/3.5	2250 kg
IRB 6650S-200/3.0	2250 kg

Environment

Ambient temperature for mechanical unit	
During operation	+5 °C (41 °F) to +52 °C (122 °F)
During transportation and storage for short periods (max. 24h)	-25 °C (13 °F) to +55 °C (131 °F)
Relative humidity	Max. 95 %
Noise level	Max. 73 dB (A)
Safety	Double circuits with supervision, emergency stops and safety functions, 3-position enable device
Extended safety	SafeMove2
Emission	EMC/EMI-shielded
Options	Foundry Plus 2, LeanID

Data and dimensions may be changed without notice.

We reserve the right to make technical changes or modify the contents of this document without prior notice. With regard to purchase orders, the agreed particulars shall prevail. ABB does not accept any responsibility whatsoever for potential errors or possible lack of information in this document.

We reserve all rights in this document and in the subject matter and illustrations contained therein. Any reproduction, disclosure to third parties or utilization of its contents – in whole or in parts – is forbidden without prior written consent of ABB. Copyright © 2019 ABB. All rights reserved.

Movement

Axis movement	Working range	Axis max. speed
Axis 1 rotation	+180° to -180°	100°/s
Axis 2 arm	+160° to -40°	90°/s
Axis 3 arm	+70° to -180°	90°/s
Axis 4 wrist	+300° to -300°	150°/s
Axis 5 bend	+120° to -120°	120°/s
Axis 6 turn	+360° to -360°	235°/s

Working range, IRB6650S-90/3.9

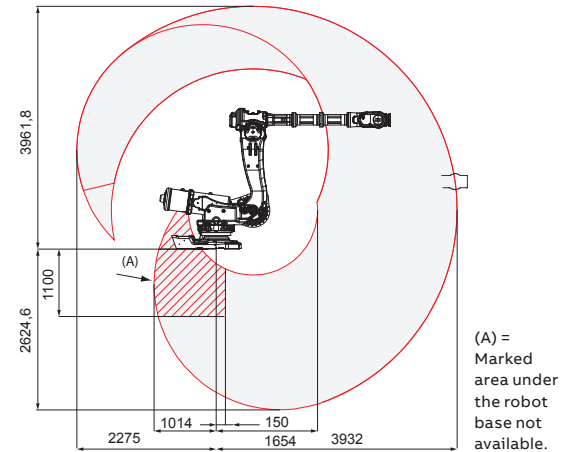

Working range, IRB6650S-125/3.5

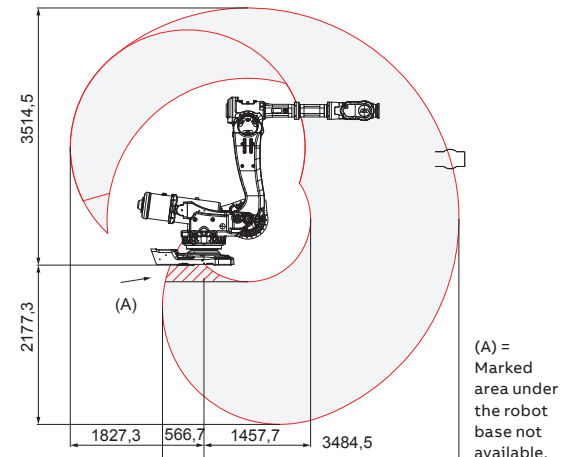

Working range, IRB6650S-200/3.0

